

# STERIFLO<sup>®</sup>

## WASTEWATER DISINFECTION WITH ULTRA-VIOLET LIGHT

*We give you the choice*

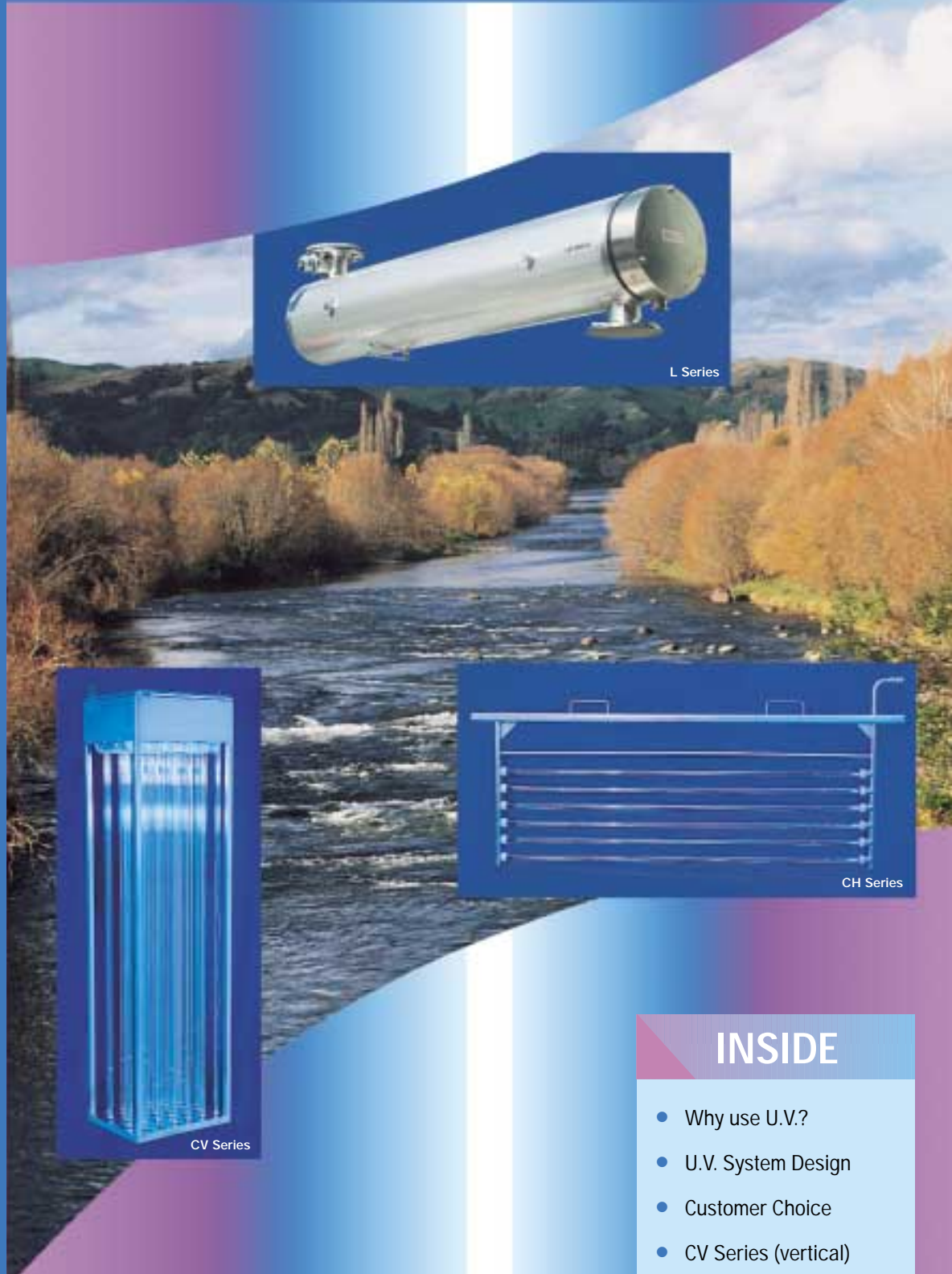

L Series



CV Series



CH Series

### INSIDE

- Why use U.V.?
- U.V. System Design
- Customer Choice
- CV Series (vertical)
- CH Series (horizontal)
- System C Controls
- L Series (chamber)

## Why use UV?

All around the world regulations concerning wastewater discharges are tightening in response to recognition of the environmental impact of pathogenic micro-organisms in both coastal areas and inland waterways.

Wherever wastewater is discharged, to sea, river, wetland or for irrigation, control of the level of micro-organisms is required. When used correctly ultra-violet (UV) light can ensure that wastewater discharges are disinfected without the addition of chemicals and their associated byproducts.

Chlorine in particular has been identified as the direct source of many potentially carcinogenic compounds in wastewater and its use is increasingly difficult to justify. Chlorine also has many hidden costs in safety, handling and operator training in the use of this toxic chemical.

UV systems are compact with only seconds retention time, compared to the half hour or so required for chlorine, and can even be fitted into decommissioned chlorine contact tanks. Operating costs are lower than for chlorination or ozonation, and most importantly, UV is

effective against a wide range of organisms.

Therefore, whatever indicator organism is selected as appropriate for monitoring the plant discharge, UV disinfection ensures effective treatment of the widest possible range of bacteria and viruses.

**Compared to ozone and chlorine, meeting the required level of indicator organisms with UV ensures a better kill of other species of concern.**

Micro-organisms are constantly reproducing to live and to cause a problem must have good conditions for growth. The correct wavelengths of UV light damage the reproductive ability of micro-organisms to the extent that they cannot replicate and quickly die. UV wavelengths around 260nm are the most effective and the most cost effective source is the low pressure mercury vapour lamp. **This proven lamp is used in hundreds of thousands in the great majority of UV facilities around the world** because it is electrically the most efficient method of producing the correct germicidal wavelength. While other lamps can produce more UV they cost more and are a less efficient method of converting input electricity into germicidal UV.

In addition the low pressure lamps are made by several manufacturers and are therefore readily available so the purchaser is not tied to one supplier.

## UV system design

Unalterable facts dictate the essentials of UV system design. The lamp must be protected from the water and a high quality quartz sleeve surrounding the lamp, with water flowing around the tube, is the most efficient design to maximise the use of UV. The wastewater absorbs UV and therefore the spacing between lamps is defined within limits, otherwise too little UV is available in places.

The most important parameter in UV system design is UV dose (UV intensity x exposure time), measured in mWs/cm<sup>2</sup> - or in microWs/cm<sup>2</sup> (1mWs/cm<sup>2</sup> = 1,000 microWs/cm<sup>2</sup>). Therefore as well as the lamp output being considered, exposure or residence time has to be included.

The majority of initial wastewater UV development took place in North America and many exotic designs were evaluated and have failed. What Contamination Control offer is a comprehensive range of UV systems for wastewater treatment based on three simple, proven and effective designs with components such as lamps, quartz sleeves and power supplies common to all models. These designs are in successful use in Australia, New Zealand and the Pacific Islands.

## Customer choice

Our range is wider and more flexible than that offered by any other manufacturer. Three basic designs are available. This means the end user gets the most appropriate system possible, designed to suit the wastewater plant and its operation, maximising operator convenience and keeping operating costs as low as possible.

**For open channels the choice is between vertical lamps (CV series) in modules of thirty or thirty six, or horizontal racks with four to ten lamps per rack (CH series).**

These modules or racks can be arranged to suit the plant as required.

**For pressurised flows the L series of enclosed treatment chamber systems are available but the open channel systems are more common.**

In the case of lower flows (below 10 lps) the horizontal CHP package rack systems are available and are described in a separate leaflet.

All these systems are designed to achieve the required level of disinfection. Full details of flow rates, wastewater treatment, wastewater quality and required discharge bacteria levels are necessary to assist in designing the plant, not only to achieve the required disinfection but to ensure that the plant is operator friendly and economical to run.

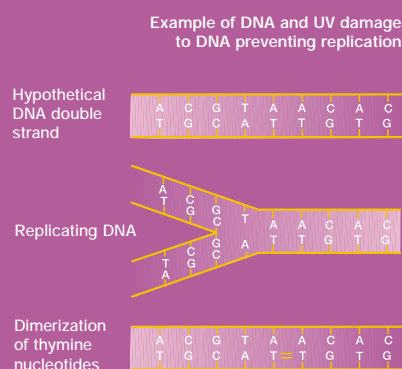
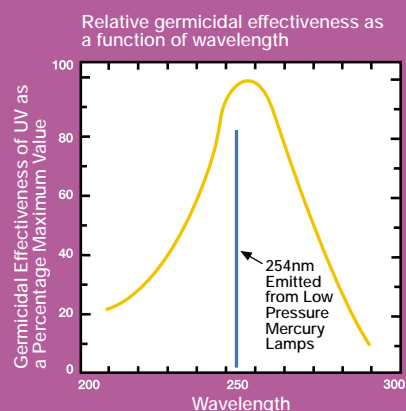

# CV Series (vertical lamp)

The most striking feature of CCL vertical lamp UV systems is that all the electrical components such as connectors and wiring are in an enclosure above the channel, mounted on top of the lamp module. This means that wastewater ingress to these components is physically impossible. While the quartz sleeves are sealed in the same way as horizontal systems the seals are actually more than 100mm above the maximum water level.

This means that the vertical design is the safest of all possible options. It is also the most convenient in several ways. No disassembly is required for lamp replacement, merely lift the lid of the module and unplug the lamp, lift it out and replace it.

In practice vertical modules may never require disassembly - a major benefit.



Manukau City has installed a vertical module UV system at the Beachlands/Maraetai sewage treatment plant.

## Channel requirements - vertical modules

The modules fit into a channel 510mm wide (or multiples if modules are fitted side by side) and 1,700mm deep. Channel length depends on the number of modules required and the method of level control used.

The CV modules contain thirty or thirty-six lamps and are installed in a series configuration (the maximum number per channel in series is eight). The modules can be fitted in pairs to allow up to sixteen modules per channel.

The great benefit arising from fitting the modules in series in a single channel is that the number operating can be varied in relatively small stages. The PLC controller can respond to variations in flow or water quality by switching modules, without operator involvement in opening penstocks to parallel channels or investment in motorised penstocks. The single channel approach is likely to be the lowest cost to build and to operate.

CCL supply precise channel dimensions and it is essential for trouble free installation that channel construction is accurate.

## CV Series features

- Most efficient use of UV energy, due to smaller flow-pacing increments
- Lower overall operating and construction costs
- All electrical connections are above water level
- Clean in place or remove module for cleaning.
- No disassembly to change lamps

Vertical module.

SYSTEM	NO. OF LAMPS	POWER CONSUMPTION (kW)	CAPACITY l/sec
CV30	30	2.55	15-36
CV36	36	3.06	16-45

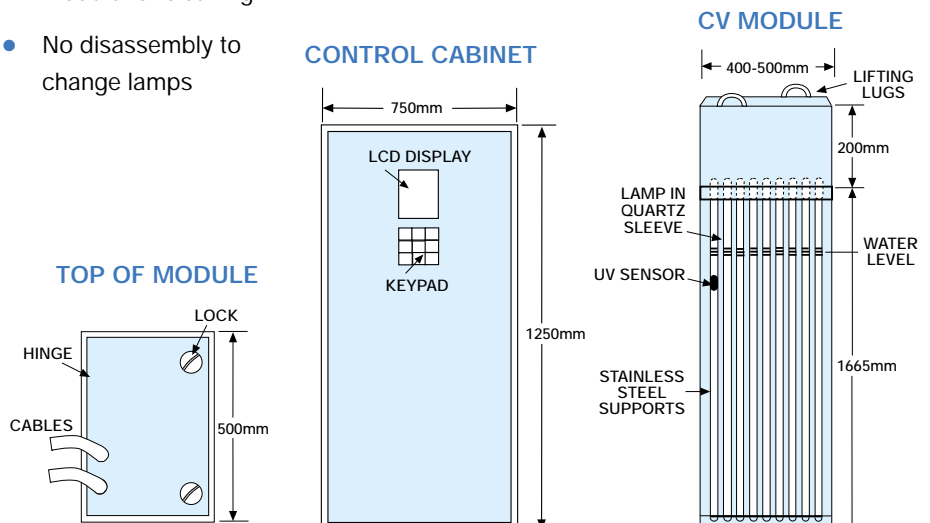

\* Dimensions will change with model

# CH Series (horizontal lamp)

The horizontal rack arrangement of UV lamps is the commonest of all in wastewater treatment. It is flexible in that the number of racks per channel and the number of lamps per rack can be varied to suit the site and is therefore ideal for retrofitting to existing plants. Two or three banks can be fitted to a channel.

Parallel channels can also be installed to increase the number of flow steps available.

In the horizontal system all the lamp is under water including the electrical connector. In the event of a water leak into the rack the earth leakage system will detect leakage of current to earth and will shut the rack(s) down. The system control PLC continuously monitors and displays earth leakage current.

Horizontal systems are ideal for smaller installations as they require shallow channels (which can be prefabricated). The racks are easily removed for cleaning by a single operator.

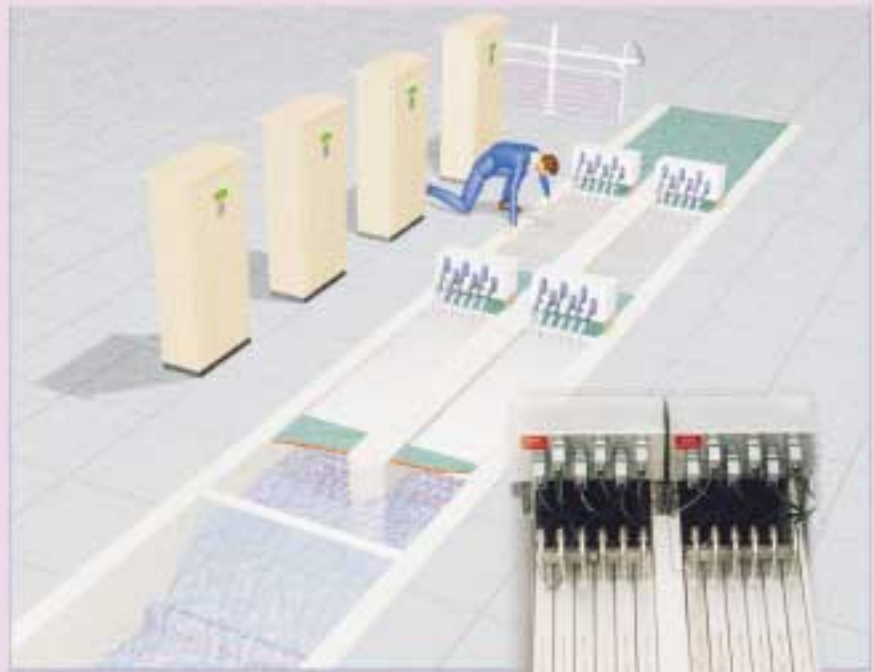

Horizontal rack UV systems are the most common design worldwide.

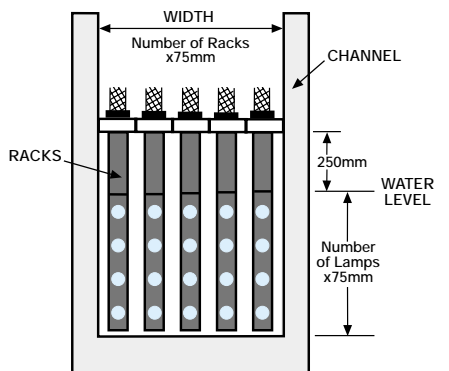
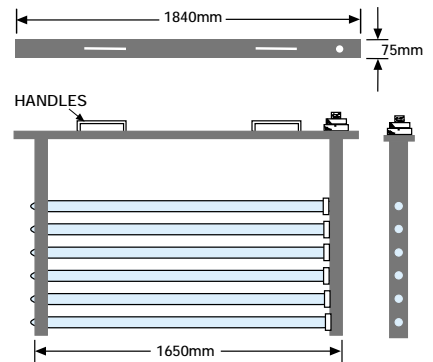

## Channel requirements - horizontal racks

The flexibility of the rack design means that any number of lamps can be fitted to a rack, from four to ten is typical but the racks can have even more lamps if necessary.

From four to ten racks will be in a bank, making the number of lamps in a bank anything from eight to one hundred.

The channel dimensions therefore depend on the number and arrangement of the lamps in the modules, but will be from 300mm to 1,000mm deep. Length depends not only on the number of banks (one, two or three) but also the required spacing between the banks and the approach length to the first bank.

As noted for the vertical system CCL provide

detailed dimensions for the channel and accuracy of construction is essential.

## CH Series features

- Easy to retrofit to existing channels
- Racks are easy to remove for manual cleaning
- Each lamp separately indicated on control panel
- Most common design worldwide
- Suits smaller plants

NO. OF LAMPS (Per rack)	POWER CONSUMPTION (Watts)	CAPACITY l/sec
4-10	85/lamp	0.5-1.4 (per lamp)



At Healesville (Victoria) the town's wastewater is disinfected with UV prior to entering the Yarra River which flows through Melbourne.

# Influence of wastewater quality on treatment capacity.

In sizing UV systems attention must be given to the water quality. Most important is UV transmittance (or absorbance). This is a measurement in a 1cm path length cell of how much UV light is transmitted (or absorbed) by matter dissolved or suspended in the water. Distilled water is 100% and wastewater, dependent on treatment quality, can range from 20% to 80%. The more UV absorbed, the lower the flow treated per lamp.

The table below gives some approximate capacities per lamp at various water qualities to achieve <200 faecal coliforms per 100ml. Consult CCL for site specific recommendations.

WATER QUALITY BOD/SS (mg/l)	%UV TRANSMISSION (1cm)	FLOW PER LAMP l/sec
30 - 30	40	0.5-0.75
20 - 20	50	0.75-1.2
10 - 10	65	1-1.4

Suspended solids influence transmittance to some extent, but of greater importance is the ability of suspended solids to shield micro-organisms. UV systems are capable of achieving single figure counts of indicator organisms at suspended solids levels below 10mg/l, but as suspended solids levels increase so does the proportion of bacteria that are inaccessible to the UV light. The nature of the suspended solids also has a major effect - biomass flocs from an activated sludge system will contain more bacteria than clay particles from a wetland for example.

Wastewater from an oxidation pond will have much lower indicator organism counts than effluent from rapid, highly aerated processes. As UV is a % reduction process less UV would be required to achieve a given outlet count given a low influent count.

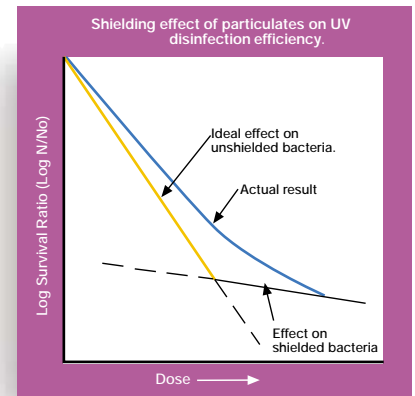
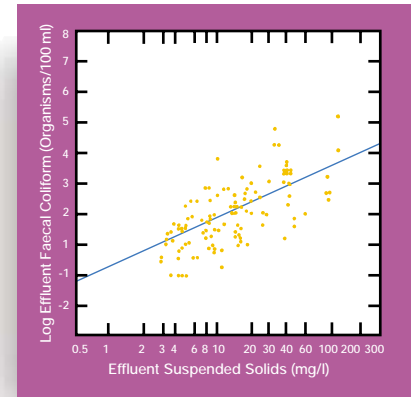

## “System C” controls

Standard equipment with both Steriflo CV and CH channel systems is the PLC controlled power supply and control cabinet (PSC).

Each vertical module or horizontal bank of lamps has its own PSC, monitoring earth leakage, UV output, lamp and transformer operation plus general electrical cabinet parameters such as temperature and cooling fan or anticondensation heater operation. All monitored functions have alarm levels that can be altered in the field, some like UV intensity have two alarm levels - low and extra low.

System C alarms can be assigned to several different outputs for local or remote monitoring of status. All functions are addressed through the menu driven keypad, which is accessed through an operator password. Alarms are chronologically recorded in memory and can be viewed by the operator. Altering of alarm levels and access to maintenance functions are carried out using a higher level password.

System C offers a higher degree of flexibility than other PLC driven systems as different banks or modules can be assigned differing operational parameters, for example one module can be operated manually as a

baseload system while others can be operated on a time basis (to coincide with diurnal flows) or can be activated by input from a flowmeter.



### Features:

- Enclosure earth leakage protection
- UV lamps earth leakage protection
- PLC control (keypad access)
- Password access control
- Anticondensation heater
- Cooling fan
- PSC high temperature alarm
- UV intensity display
- 4-20 mA output (optional)

## System C - UV control system specification

**Power consumption**  
(30 lamps including PSC) - 2.55kW.

**Power supply** - Three phase, with power factor correction.

**Power supply and control cabinet construction** - GRP with internal steel frame (304 stainless steel cabinet optional).

**PSC dimensions**  
(includes rain cover and base)

Height: 1,350mm

Weight: 250kg approx.

Width: 850

Weather rating: IP54

Depth: 340

- PSC over temperature safety cut-out
- Lamp module safety interlock
- Programmable alarm output contacts
- Alarm indicator
- Alarm accept
- Chronological alarm listing
- Remote operation
- Power factor correction
- Hours run display

## Pilot plants

The design and operation of municipal wastewater plants is in general well understood with over 1,000 systems in operation in Nth. America alone and increasing numbers in Australia and New Zealand.

Current installations are almost invariably open channel designs. However pilot work is still useful particularly to assess fouling rates and the effect of different cleaning regimes or of variations in effluent quality.

In industrial applications, or when a significant industrial component is present in a municipal wastewater, pilot testing is usually essential.

Once a preliminary assessment and budget cost exercise has been carried out a plant trial can take place, usually for a month or more. Trial equipment is available from Contamination Control Ltd.

## Industrial use

Most wastewater UV installations are built to reduce the impact of wastewater on receiving waters or to allow its use for irrigation.

To a certain extent this applies to industrial wastewater, particularly from food processing. In industry however the emphasis is on re-use, so that both fresh water demands and wastewater treatment or discharge costs are reduced. The wastewater may simply be storm water in which case re-use is relatively simple.

However in many cases the wastewater may be high strength containing high levels of dissolved BOD and COD or other components which may cause fouling or reduce the effectiveness of the UV system.

Applications like this are best trialed using pilot plants prior to the design of a full scale plant.



## Safety first

System C offers safe and comprehensive control of the electrical and electronic operation of the plant. Safety with UV light is also addressed in that if any racks are removed from the channel, or if a vertical module cover is lifted, that bank or module is automatically switched off by 24 volt safety interlock. Covers are specified over the channel which act as eyeshields for operators close to the channel. Contamination Control Ltd will routinely check UV levels around the channel as part of the commissioning process.



## Ease of cleaning

With every UV system cleaning of the sleeves around the lamps will be required from time to time. Frequency is site specific but will depend on the suspended solids, organic and mineral content of the wastewater. In CCL channel systems treatment is usually maintained during cleaning. A variety of cleaning methods are available and generally involve removing a rack or module from the channel to a cleaning station or tank. Mild acids such as citric are usually employed.

A major objective of CCL designs is to keep them simple to clean. Operators then are able to maintain clean sleeves without difficulty. In place systems such as air scouring are frequently included in CCL recommendations as they have been found effective in prolonging the interval between cleans. For large installations with more than one channel it is often practical to clean in 'situ' using the air scour to agitate acid in the channel.

## Level control

The appropriate method of level control in channel systems is dependent on the upstream plant's operation and flow rates. A head driven flap gate is common for plants with continuous flows but for intermittent or periodically static flows and smaller plants a weir is best.

Weir length calculation and selection of an appropriate design is carried out by CCL in consultation with the customer's engineers. With either arrangement the ability to clean debris out of the channel is required.

The flap gate style is compact but a weir will maintain level even at zero flow.

## Plant location

Wastewater treatment plants have aggressive, corrosive environments and the Steriflo range is manufactured to handle it. All metal components are stainless steel, all wetted components being 316L. Both channel and chamber designs are weather proof. For all weather servicing, particularly of larger plants a basic weather shelter is advisable. Space should also be allowed for washdown of racks and modules after cleaning and for maintenance tasks like lamp changing.

# Steriflo L Series chamber systems

The pressurised treatment chamber approach is ideal for pumped or recirculating flows as it avoids repumping costs. The 316L stainless steel chambers are routinely operated up to 150psi and are constructed from heavy duty schedule 10 pipe. Designs are available for 1 to 28 lamps. With smaller numbers of lamps the L series are not PLC controlled but are comprehensively equipped with, for example, earth leakage monitoring and UV intensity measurement. Individual lamp operation is monitored and any faults are shown on an LED display. Cleaning of small unit sleeves is usually done by hand. In large installations cleaning is accomplished by recirculation of dilute acid.



Sewage at Millford Sound is treated using an L Series system

## Steriflo L Series

MODEL	NO. OF LAMPS	POWER CONSUMPTION kW (single phase)	*CAPACITY		*INLET CONNECTION (flange or thread mm)
			50%T	65%T	
L1	1	0.085	0.75	1.25	50
L2	2	0.17	1.5	2.5	50
L4	4	0.34	3.0	5.0	75
L6	6	0.51	4.5	7.5	75
L9	9	0.77	6.75	11.5	100
L14	14	1.19	10.5	17.5	100
L22	22	2.02	16.5	27.5	150
L28	28	2.38	21.0	35.0	150

\*For guidance only - contact CCL for firm recommendation

## L Series features

- Pressurised system - no repumping
- Minimal civil works
- 150 psi pressure rating
- Chemical cleaning connections standard
- 316L stainless steel construction

## L Series Specifications

<b>Wetted parts:</b>	Quartz, Silicone rubber, 316L Stainless steel
<b>Pressure rating:</b>	150psi (1034 kPa)
<b>IP rating:</b>	IP54
<b>Control cabinet</b>	GRP with clear front panel insert.

### CHAMBER DIMENSION (APPROX)\*

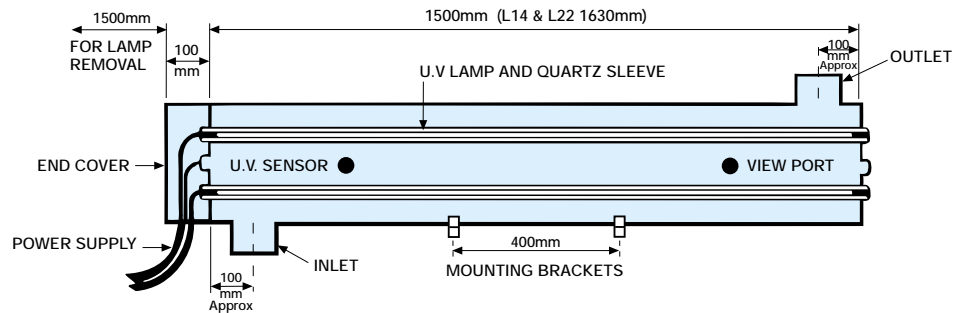

### CHAMBER CROSS SECTION

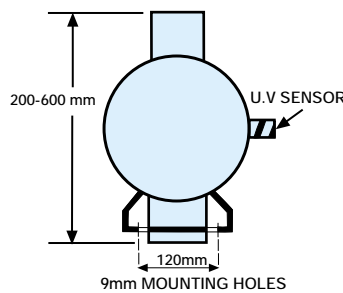

### CONTROL PANEL LAYOUT (L6)

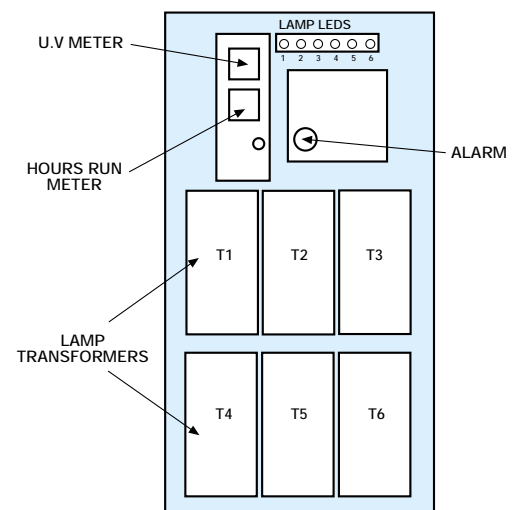

\* Dimensions will change with model.

## *We give you the choice*

The Steriflo range is the widest available in wastewater disinfection, and the most appropriate system can therefore be selected to meet the client's requirement. Most UV manufacturers offer only one option, whether it is the most appropriate or not. Considerations of operating economy, safety, ease of use, upstream operation, suitability for retrofit or future expansion are all potentially critical in the selection of an ultra-violet disinfection system.

*It doesn't make sense to be limited to a single design*

## UV works.....

- ✓ Simply
- ✓ Effectively
- ✓ Safely
- ✓ Without byproducts
- ✓ Economically
- ✓ Fast
- ✓ For you

Further enquiries may be made to:



**CONTAMINATION  
CONTROL  
LIMITED**

NEW ZEALAND:  
P.O.Box 14 621, Auckland,  
New Zealand.  
Ph: 0-9-570 9135  
Fax: 0-9-527 7654

IN AUSTRALIA:  
**Memtec Ltd.**,  
Locked Mailbag 1,  
Windsor NSW 2756,  
Ph: 045-776800  
Fax: 045-776804